

Linear Motion Control Applications

Gantry Systems

Controlling motion on all axes, Nexen's Servomotor Brakes, Ball Screw Brakes and Profile Rail Brakes provide precise holding with little or no backlash. Also, Nexen's Roller Pinion System enables gantrys to move long distances, at high speeds with no accumulated error and zero backlash.

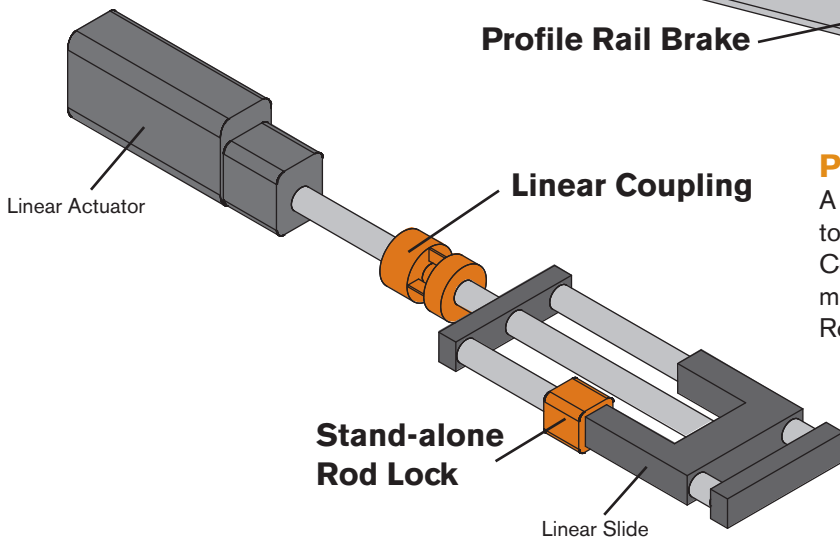
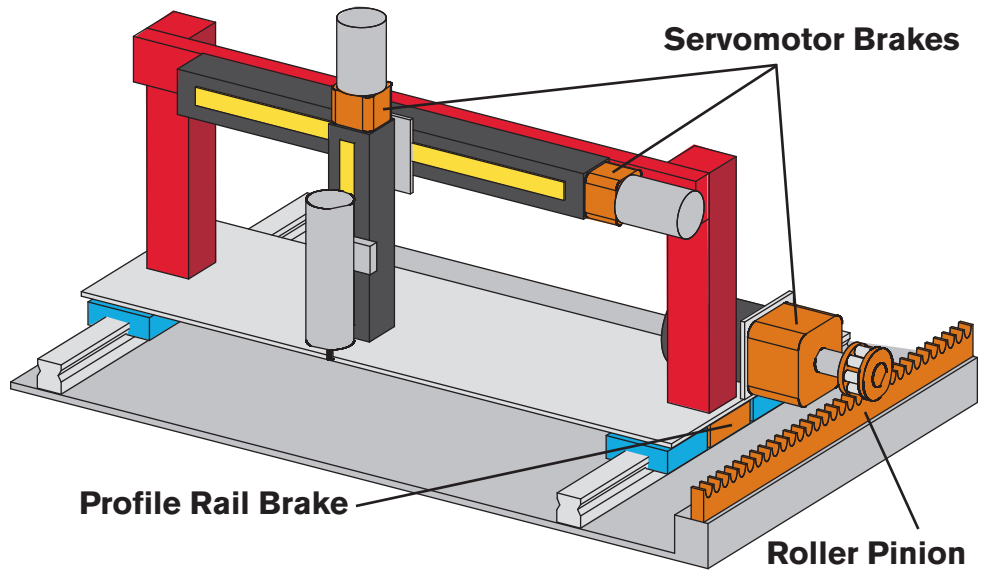

Positioning System

A linear actuator is precisely coupled to a linear slide using a Nexen Linear Coupling. Once the guide rods have moved to their destination, a Nexen Rod Lock holds them in position.

Mechanical Torque Limiter

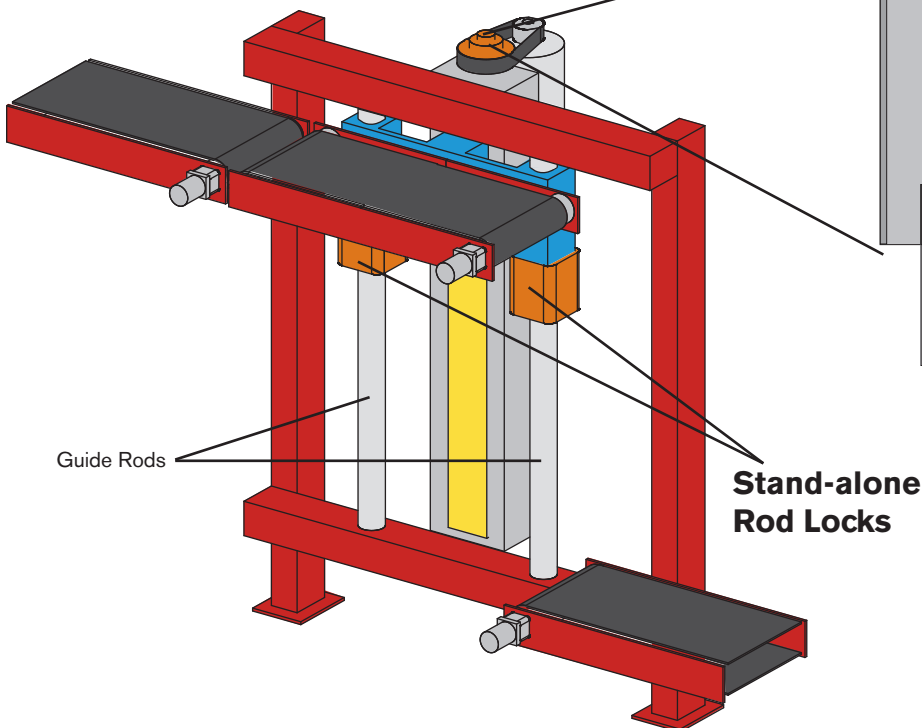
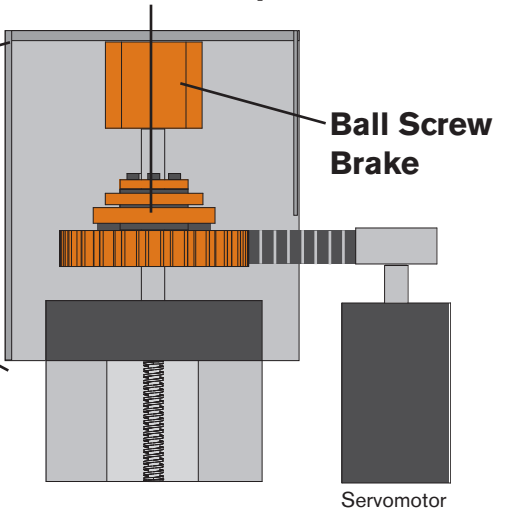

Conveyor Transfer

As conveyor segments move vertically along guide rods, Nexen's Rod Locks precisely hold position. The Mechanical Torque Limiter prevents damage to the ball screw-driven linear actuator from excessive conveyor loading.

Profile Rail Brake

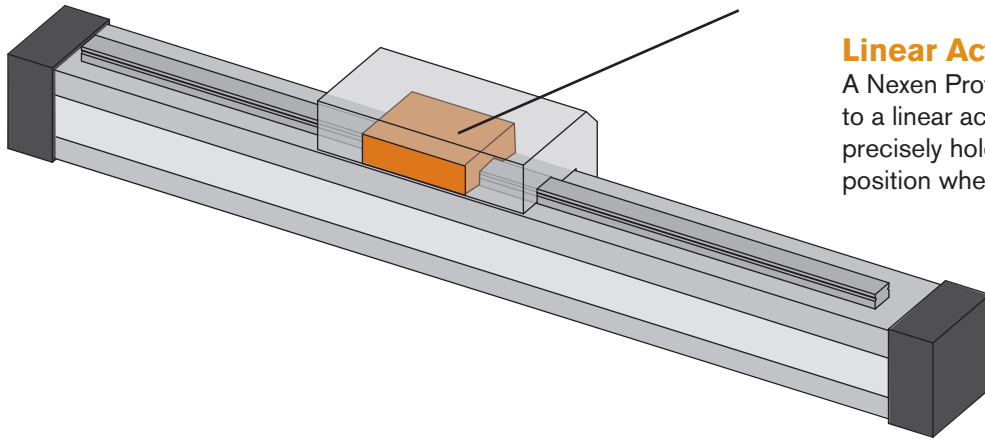

Linear Actuator Systems

A Nexen Profile Rail Brake, mounted to a linear actuator's carriage, precisely holds the carriage's position when stopped.

Linear Bridge Plate System

Nexen's Roller Pinion System enables bridge plates to move long distances, at high speeds with no accumulated error and zero backlash. Servomotor and Profile Rail Brakes compliment the system by providing e-stop and holding capabilities in all axes.

Servomotor or Pinion Brake

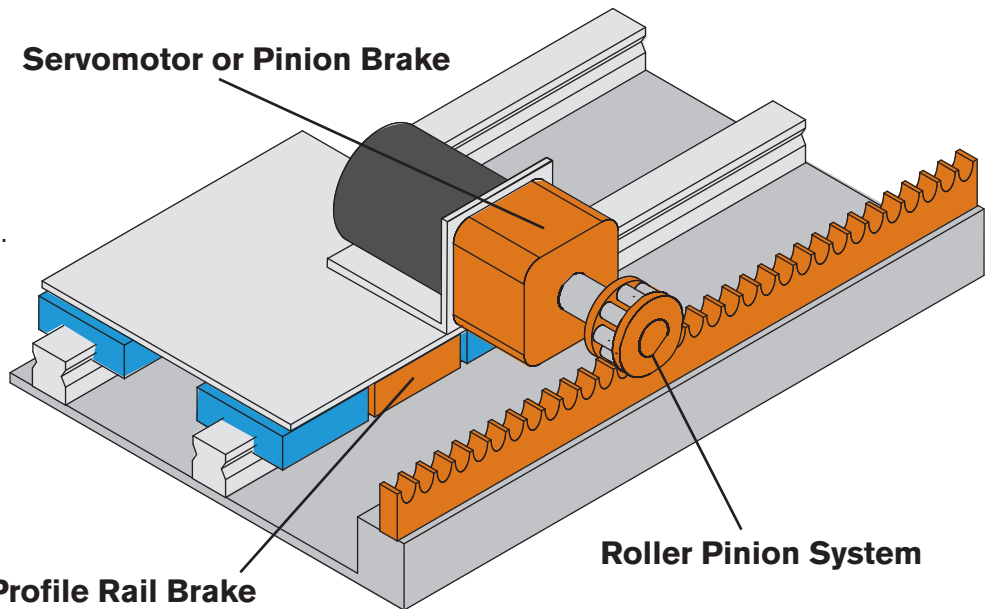

Roller Pinion System

Profile Rail Brake

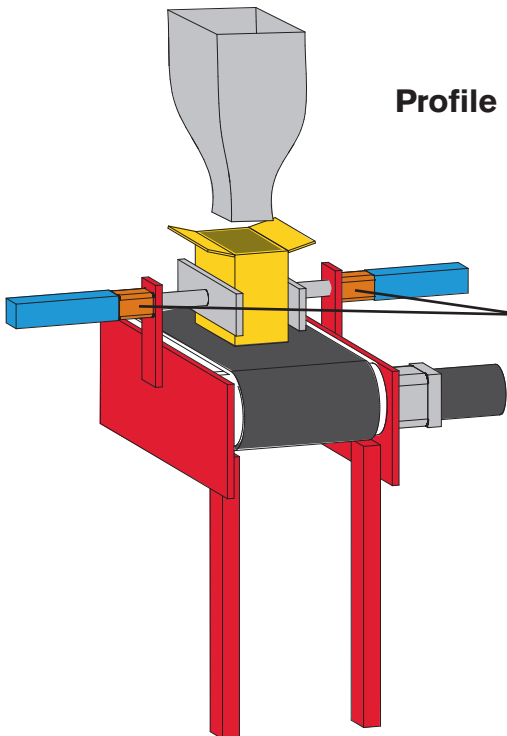

Cylinder-mounted Rod Locks

Filling Operations

As the container moves along a conveyor to the filling station, pneumatic cylinders accurately position the container under the product filling mechanism. Nexen Rod Locks hold the cylinder rods in precise position during the filling operation.